

NO	QTY	PART NO	DESCRIPTION	STD SEAL KIT	FKM SEAL KIT
1	1	21500009	SCREW, CAP, BTNH, M10 X 16, ALY		
2	2	21500018	SCREW, CAP, SOCH, M3 X 5, ALY		
3	2	21500200	WASHER		
4	3	23600011	BALL, STEEL, ALLOY, .187	X	X
5	1	29740200	SENSOR, ULTRASONIC, M12, 1m		
6	1	39010018	SEAL,CROWN,11/16x7/8x5/32	X	39V10018
7	1	39010020	SEAL,BEVEL W/HEEL INSERT,5/8 x 1/8 x 7/8	X	39V10020
8	2	39050042	O-RING, (-011)	X	39051025
9	1	39051031	O-RING, (-912)	X	X
10	1	39053001	WIPER,SNAP-IN, (5/8)	X	X
11	1	43000040	O-RING, DIN3869, M18		
12	2	43068004	PLUG, SOCH, G1/8		
13	1	47510915	PLUNGER, SC, HS, 1100/4.9KN, RH, US		
14	1	81400081	RETAINER, SC, HS, 1100, US		
15	3	90199957	ASSY,BALLSEAT,SC,1100	X	X
16	1	39F54001	BU RING,(-208 CUSTOM)	X	X
N/A	N/A	60414502	KIT, SEAL, STANDARD	INCLUDED IN KIT	
N/A	N/A	6V414502	KIT, SEAL, FKM		

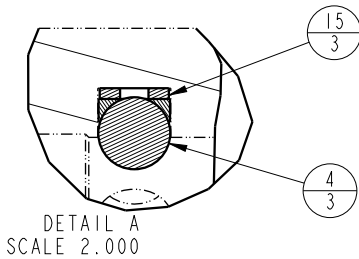
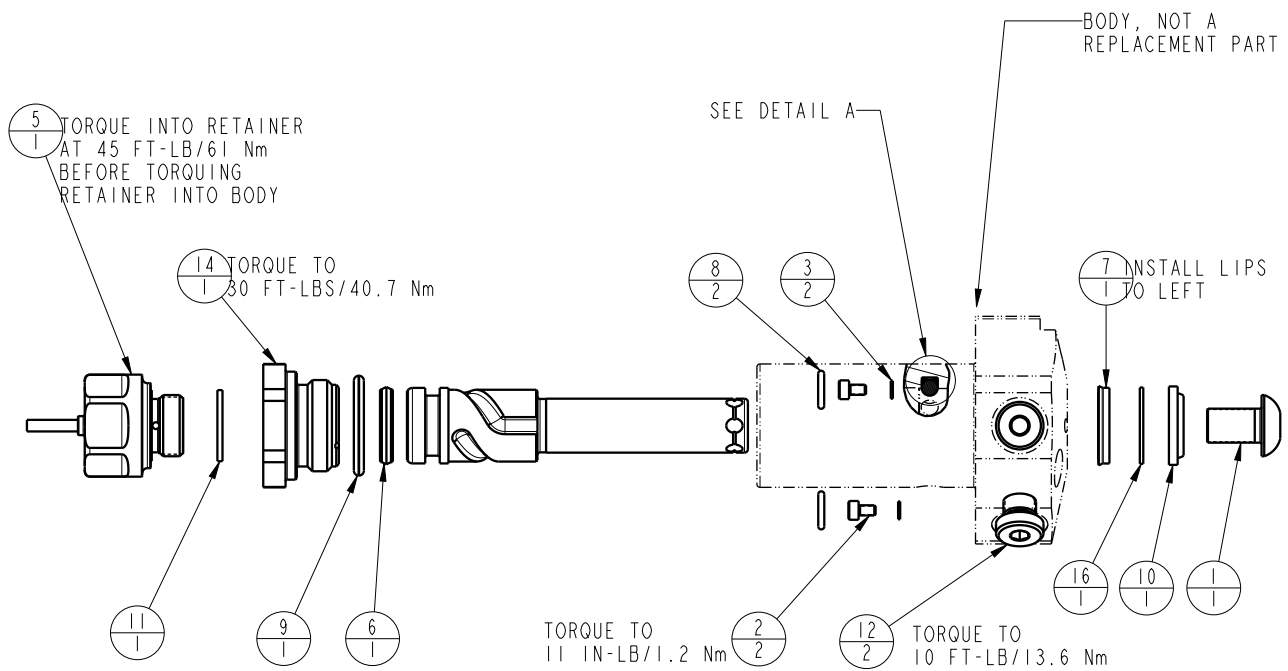

<b>PARTS LIST</b>	
	VEKTEK, INC. 1334 E. SIXTH AVE. P.O. BOX 625 EMPORIA, KS. 66801 U.S.A.
ASSEMBLIES AFFECTED 41460521US	PARTS LIST, ASSY, SC, TF, TC, A. 9KN, DA, RH, US
SIZE A	MPL1442
REV A	REV A

A	5660	RELEASE	ALS	3/24/25
REV	IN ACCORDANCE WITH ECN	EFFECTIVE DATE	REVISED BY	DATE
DRW BY: ALS	<b>DRAWING STATUS: Released</b>			
DATE: 2/5/25	PRODUCTION APPROVED FOR RELEASED STATUS ONLY			